

# A系列自润滑链条 Sintered Bushing Chains (A Series)

■ 单排、双排 Simplex / Duplex

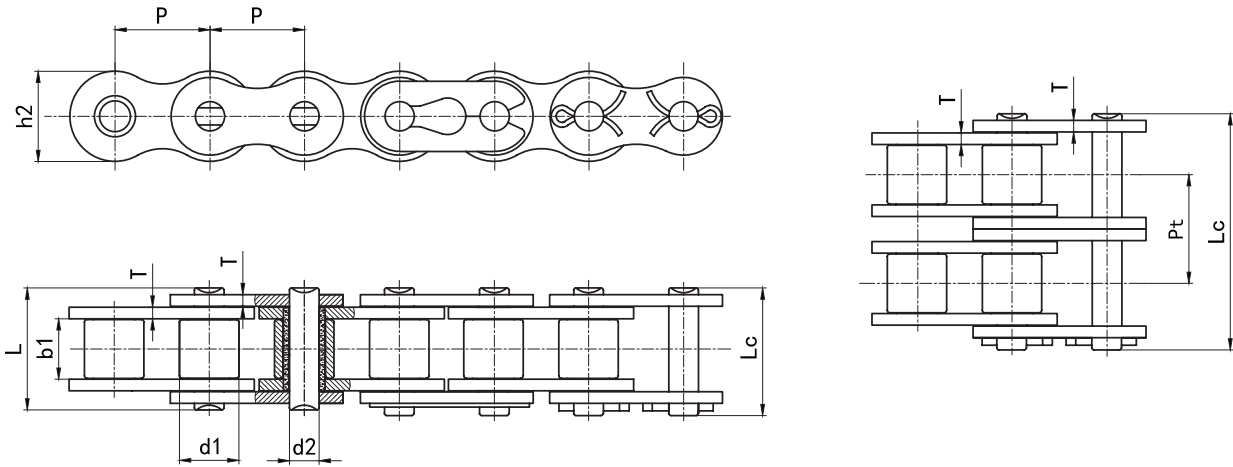

征和链号 CHOHO Chain No.	节距	滚子直径	内节内宽	销轴直径	销轴长度		内链板高度	链板厚度	排距	抗拉强度	每米重量
	Pitch	Roller diameter	Width between inner plates	Pin diameter	Pin length		Inner plate depth	Plate thickness	Transverse pitch	Ultimate tensile strength	Weight per meter
	P	d1 max	b1 min	d2 max	L max	Lc max	h2 max	T max	Pt	Q min	q
	mm	mm	mm	mm	mm	mm	mm	mm	mm	kN	kg/m
40-SL-1	12.700	7.92	7.85	3.98	16.7	18.3	12.07	1.50	/	14.1	0.60
50-SL-1	15.875	10.16	9.40	5.09	20.7	23.8	15.09	2.00	/	22.0	1.00
60-SL-1	19.050	11.91	12.57	5.96	26.2	28.3	18.10	2.42	/	34.2	1.46
80-SL-1	25.400	15.88	15.75	7.94	32.9	36.4	24.13	3.10	/	56.7	2.55
100-SL-1	31.750	19.05	18.90	9.54	40.8	44.1	30.17	4.00	/	88.5	3.82
120-SL-1	38.100	22.23	25.22	11.11	50.8	54.7	36.20	4.80	/	125.0	5.60
140-SL-1	44.450	25.40	25.22	12.71	54.7	61.0	42.23	5.60	/	170.0	7.52
160-SL-1	50.800	28.58	31.55	14.29	65.5	70.0	48.26	6.40	/	223.0	10.08
40-SL-2	12.700	7.92	7.85	3.98	31.2	33.3	12.07	1.50	14.38	28.2	1.12
50-SL-2	15.875	10.16	9.40	5.09	39.1	40.6	15.09	2.00	18.11	44.0	1.96
60-SL-2	19.050	11.91	12.57	5.96	49.1	50.8	18.10	2.42	22.78	68.4	2.89
80-SL-2	25.400	15.88	15.75	7.94	62.1	65.5	24.13	3.10	29.29	113.4	5.39
100-SL-2	31.750	19.05	18.90	9.54	76.6	80.5	30.17	4.00	35.76	177.0	7.72
120-SL-2	38.100	22.23	25.22	11.11	96.3	100.2	36.20	4.80	45.44	250.0	11.63
140-SL-2	44.450	25.40	25.22	12.71	103.6	110.1	42.23	5.60	48.87	340.0	15.21
160-SL-2	50.800	28.58	31.55	14.29	124.1	128.6	48.26	6.40	58.55	446.0	20.25
40-SL-3	12.700	7.92	7.85	3.98	45.5	47.1	12.07	1.50	14.38	41.7	1.90
50-SL-3	15.875	10.16	9.40	5.09	56.9	58.3	15.09	2.00	18.11	65.4	3.09
60-SL-3	19.050	11.91	12.57	5.96	71.8	73.6	18.10	2.42	22.78	93.9	4.54
80-SL-3	25.400	15.88	15.75	7.94	91.8	95.1	24.13	3.20	29.29	166.8	7.89
100-SL-3	31.750	19.05	18.90	9.54	112.1	116.7	30.17	4.00	35.76	261.0	11.80
120-SL-3	38.100	22.23	25.22	11.11	141.3	145.2	36.20	4.80	45.44	375.0	17.53
140-SL-3	44.450	25.40	25.22	12.71	152.0	157.9	42.23	5.60	48.87	510.0	22.20
160-SL-3	50.800	28.58	31.55	14.29	181.8	186.3	48.26	6.40	58.55	669.0	30.12

Conveyor Chains

Leaf Chains

Driving Chains

Keyway And Thread

Sprocket - A Series

Sprocket - B Series

Double Pitch Sprocket

Double Drive Sprocket

Synchronous Pulley

# B系列自润滑链条 Sintered Bushing Chains (B Series)

■ 单排、双排 Simplex / Duplex

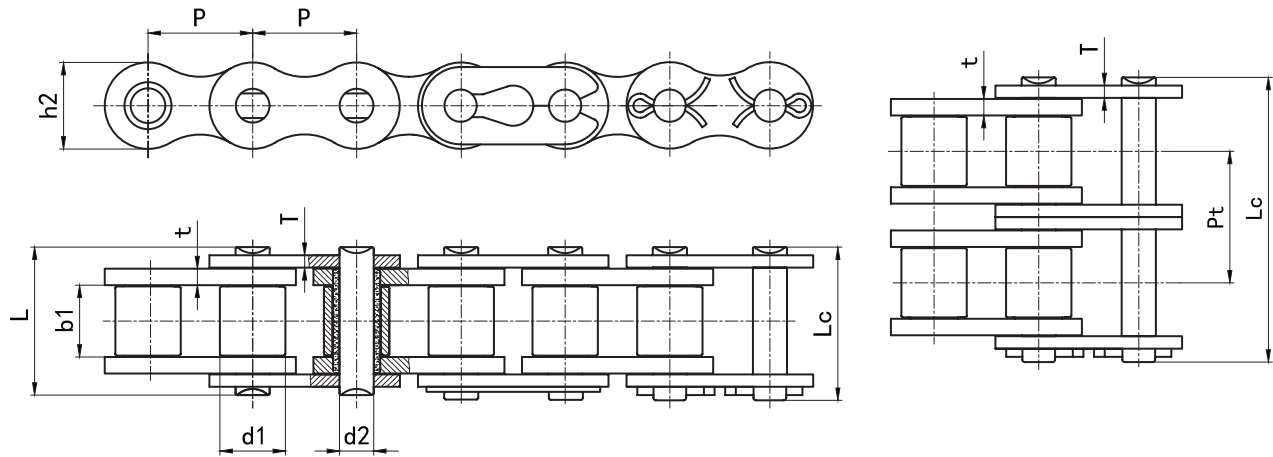

征和链号 CHOHO Chain No.	节距	滚子直径	内节内宽	销轴直径	销轴长度		内链板高度	链板厚度	排距	抗拉强度	每米重量
	Pitch	Roller diameter	Width between inner plates	Pin diameter	Pin length		Inner plate depth	Plate thickness	Transverse pitch	Ultimate tensile strength	Weight per meter
	P mm	d1 max mm	b1 min mm	d2 max mm	L max mm	Lc max mm	h2 max mm	t/T max mm	Pt mm	Q min kN	q kg/m
08B-SL-1	12.700	8.51	7.75	4.45	17.0	19.2	11.81	1.60	/	18.0	0.69
10B-SL-1	15.875	10.16	9.65	5.08	19.6	22.3	14.73	1.70	/	22.4	0.90
12B-SL-1	19.050	12.07	11.68	5.72	22.6	25.0	16.13	1.85	/	29.0	1.10
16B-SL-1	25.400	15.88	17.02	8.28	36.1	39.2	21.08	4.0/3.0	/	60.0	2.67
20B-SL-1	31.750	19.05	19.56	10.19	41.4	46.5	26.42	4.5/3.5	/	95.0	3.67
24B-SL-1	38.100	25.40	25.40	14.63	53.4	59.9	33.40	6.0/4.8	/	160.0	7.02
28B-SL-1	44.450	27.94	30.99	15.90	65.1	71.5	37.08	7.5/6.0	/	200.0	8.40
32B-SL-1	50.800	29.21	30.99	17.81	66.8	72.5	42.29	7.0/6.0	/	250.0	10.15
08B-SL-2	12.700	8.51	7.75	4.45	31.0	32.7	11.81	1.60	13.92	32.0	1.30
10B-SL-2	15.875	10.16	9.65	5.08	36.2	38.3	14.73	1.70	16.59	44.5	1.82
12B-SL-2	19.050	12.07	11.68	5.72	42.0	44.4	16.13	1.85	19.46	57.8	2.28
16B-SL-2	25.400	15.88	17.02	8.28	68.0	71.2	21.08	4.0/3.0	31.88	106.0	5.36
20B-SL-2	31.750	19.05	19.56	10.19	77.9	83.0	26.42	4.5/3.5	36.45	170.0	7.16
24B-SL-2	38.100	25.40	25.40	14.63	101.8	108.5	33.40	6.0/4.8	48.36	280.0	13.32
28B-SL-2	44.450	27.94	30.99	15.90	124.7	130.8	37.08	7.5/6.0	59.56	360.0	16.50
32B-SL-2	50.800	29.21	30.99	17.81	125.3	131.2	42.29	7.0/6.0	58.55	450.0	20.90
08B-SL-3	12.700	8.51	7.75	4.45	44.9	47.5	11.81	1.60	13.92	54.0	2.15
10B-SL-3	15.875	10.16	9.65	5.08	52.8	55.0	14.73	1.70	16.59	72.0	2.89
12B-SL-3	19.050	12.07	11.68	5.72	61.6	63.7	16.13	1.85	19.46	90.0	3.70
16B-SL-3	25.400	15.88	17.02	8.28	99.7	102.8	21.08	4.0/3.2	31.88	195.0	8.13
20B-SL-3	31.750	19.05	19.56	10.19	114.3	119.4	26.42	4.5/3.5	36.45	300.0	11.50
24B-SL-3	38.100	25.40	25.40	14.63	149.8	156.0	33.40	6.0/4.8	48.36	504.0	21.10
28B-SL-3	44.450	27.94	30.99	15.90	184.3	190.3	37.08	7.5/6.0	59.56	630.0	27.30
32B-SL-3	50.800	29.21	30.99	17.81	183.6	189.3	42.29	7.0/6.0	58.55	780.0	31.56

输送带  
Conveyor Chains

曳引链  
Leaf Chains

传动链  
Driving Chains

键槽和螺纹  
Keyway And Thread

A系列滚子链轮  
Sprocket - A-Series

B系列滚子链轮  
Sprocket - B-Series

双节距链轮  
Double Pitch Sprocket

双驱动链轮  
Double-Drive Sprocket

同步带轮  
Synchronous Pulley

# O型密封圈链条 O-Ring Chains

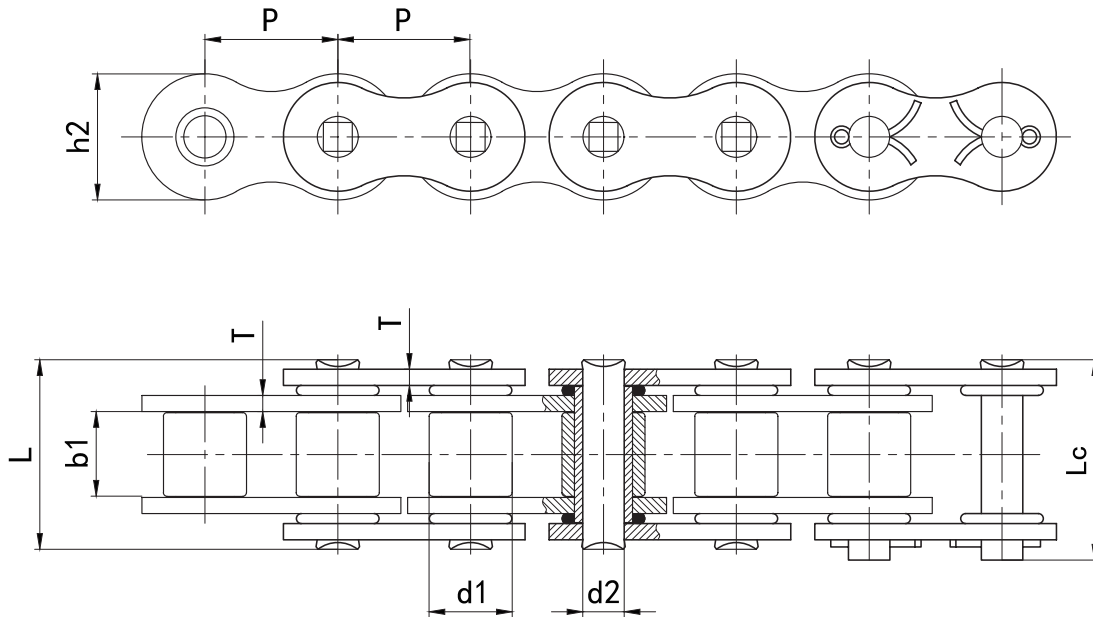

征和链号 CHOHO Chain No.	节距	滚子直径	内节内宽	销轴直径	销轴长度		内链板高度	链板厚度	抗拉强度	平均抗拉强度	每米重量
	Pitch	Roller diameter	Width between inner plates	Pin diameter	Pin length		Inner plate depth	Plate thickness	Ultimate tensile strength	Average tensile strength	Weight per meter
	P	d1 max	b1 min	d2 max	L max	Lc max	h2 max	T max	Q min	Q <sub>0</sub>	q
	mm	mm	mm	mm	mm	mm	mm	mm	kN	kN	kg/m
40-RO	12.700	7.92	7.85	3.98	18.3	19.6	12.07	1.50	14.1	17.9	0.67
50-RO	15.875	10.16	9.40	5.09	23.1	24.8	15.09	2.00	22.2	29.3	1.19
60-RO	19.050	11.91	12.57	5.96	28.5	30.4	18.10	2.42	31.8	42.0	1.62
80-RO	25.400	15.88	15.75	7.94	35.6	37.3	24.13	3.20	56.7	72.3	2.70
100-RO	31.750	19.05	18.90	9.54	43.3	47.0	30.17	4.00	88.5	110.5	3.94
120-RO	38.100	22.23	25.22	11.11	54.0	57.5	36.20	4.80	127.0	157.0	6.30

输送机  
Conveyor Chains

曳引链  
Leaf Chains

传动链  
Driving Chains

键槽和螺纹  
Keyway And Thread

A系列滚子链轮  
Sprocket - A Series

B系列滚子链轮  
Sprocket - B Series

双节距链轮  
Double Pitch Sprocket

双驱动链轮  
Double-Drive Sprocket

同步带轮  
Synchronous Pulley