

木材输送链 Lumber Conveyor Chains

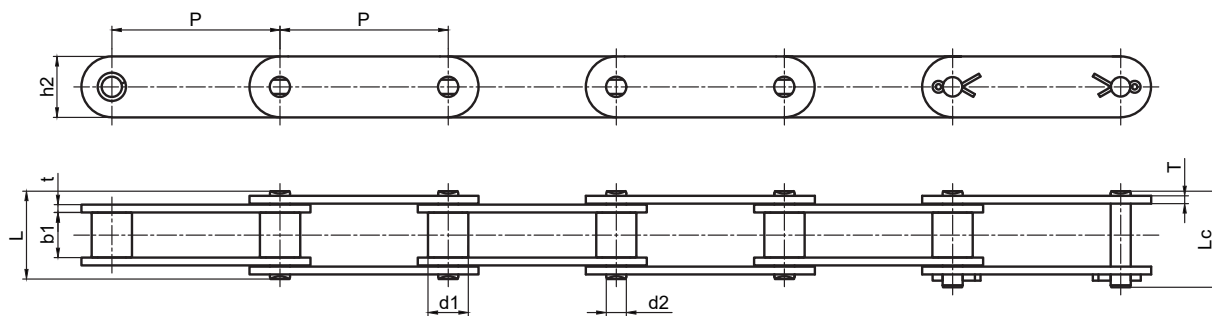

征和链号 CHOHO Chain No.	节距	滚子直径	内节内宽	销轴直径	销轴长度		内链板高度	链板厚度	抗拉强度	平均抗拉强度	每米重量
	Pitch	Roller diameter	Width between inner plates	Pin diameter	Pin length		Inner plate depth	Plate thickness	Ultimate tensile strength	Average tensile strength	Weight per meter
	P	d1 max	b1 min	d2 max	L max	Lc max	h2 max	t/T max	Q min	Q ₀	q
	mm	mm	mm	mm	mm	mm	mm	mm	kN	kN	kg/m
81X	66.27	23.02	27.00	11.1	49.9	53.5	28.60	4.00	106.7	128.9	3.78
81XH	66.27	23.00	27.78	11.1	60.7	65.1	31.35	7.94/5.55	151.9	175.7	5.88
81XHH	66.27	23.00	27.78	11.1	65.6	70.0	31.35	7.94	191.1	212.6	6.7

输送带
Conveyor Chains

曳引链
Leaf Chains

传动链
Driving Chains

键槽和螺纹
Keyway And Thread

A系列滚子链轮
Sprocket - A-Series

B系列滚子链轮
Sprocket - B-Series

双节距链轮
Double Pitch Sprocket

双驱动链轮
Double-Drive Sprocket

同步带轮
Synchronous Pulley

尖齿链 Sharp Top Chains

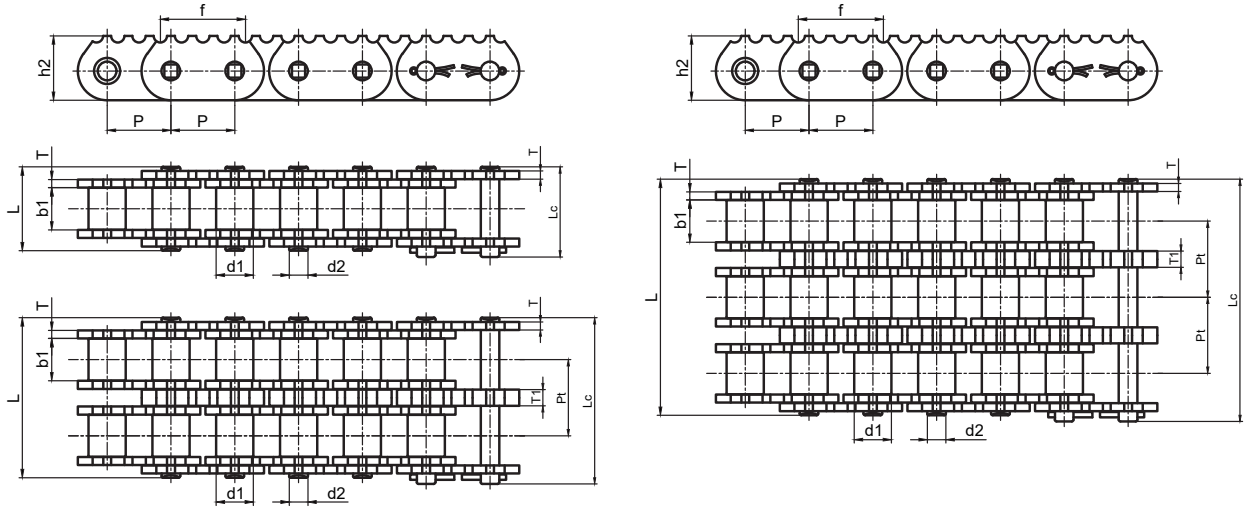

征和链号 CHOHO Chain No.	节距	滚子直径	销轴直径	内节内宽	销轴长度		链板尺寸				排距	抗拉强度	平均抗拉强度
	Pitch	Roller diameter	Pin diameter	Width between inner plates	Pin length		Attachment dimensions				Transverse pitch	Ultimate tensile strength	Average Tensile Strength
	P	d1 max	d2 max	b1 min	L max	Lc max	h2 max	T	T1	f	Pt	Q min	Q ₀
	mm	mm	mm	mm	mm	mm	mm	mm	mm	mm	mm	kN	kN
C120-1802-1	38.100	22.23	11.10	25.30	141	144.7	38.5	4.8	/	50.8	/	125	157.0
C120-1802-2	38.100	22.23	11.10	25.30	98	101.7	38.5	4.8	9.5	50.8	45.44	250	314.0
C120-1802-3	38.100	22.23	11.10	25.30	50.5	54.2	38.5	4.8	9.5	50.8	45.44	375	439.0

Conveyor Chains

Leaf Chains

Driving Chains

Keyway And Thread

Sprocket - A Series

Sprocket - B Series

Double Pitch Sprocket

Double-Drive Sprocket

Synchronous Pulley

尖齿链 Sharp Top Chains

输送带
Conveyor Chains

曳引链
Leaf Chains

传动链
Driving Chains

键槽和螺纹
Keyway And Thread

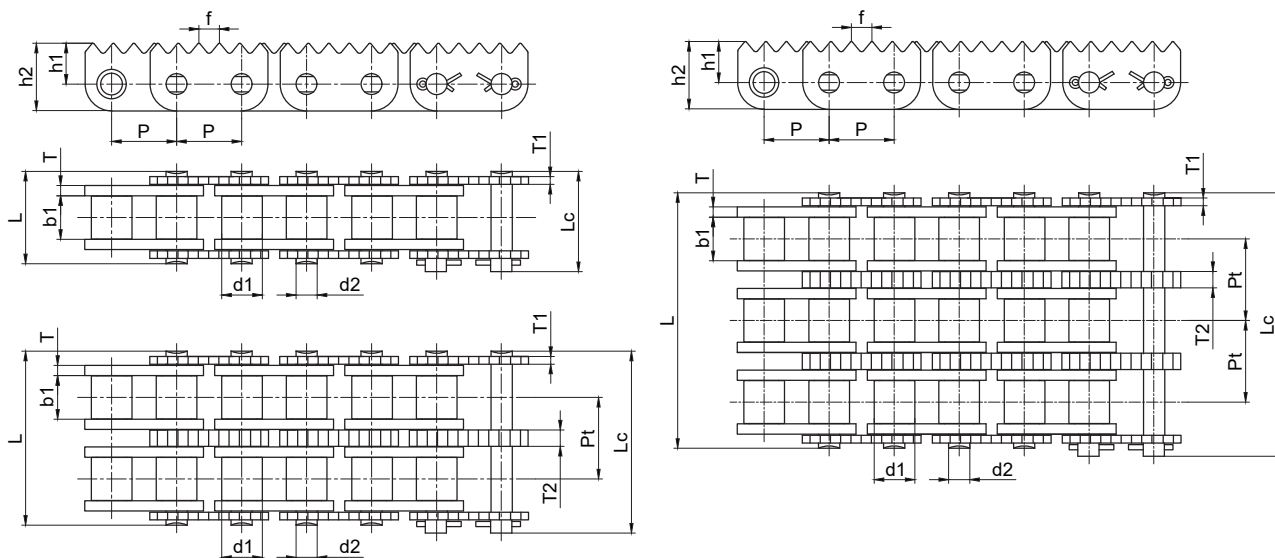

A系列滚子链轮
Sprocket - A-Series

B系列滚子链轮
Sprocket - B-Series

双节距链轮
Double Pitch Sprocket

双驱链轮
Double-Drive Sprocket

同步带轮
Synchronous Pulley

征和链号 CHOHO Chain No.	节距	滚子直径	销轴直径	内节内宽	销轴长度		链板尺寸						排距	抗拉强度
	Pitch	Roller diameter	Pin diameter	Width between inner plates	Pin length		Attachment dimensions						Transverse pitch	Ultimate tensile strength
	p	d1 max	d2 max	b1 min	L max	Lc max	h2 max	f	h1	T	T1	T2	Pt	Q min
	mm	mm	mm	mm	mm	mm	mm	mm	mm	mm	mm	mm	mm	kN
C16B-1186-1	25.400	15.88	8.28	17.02	36.1	39.2	26.5	8.0	16.0	4.0	3.0	/	/	60.0
C16B-1186-2	25.400	15.88	8.28	17.02	68.0	71.2	26.5	8.0	16.0	4.0	3.0	6.4	31.88	106.0
C16B-1186-3	25.400	15.88	8.28	17.02	99.8	102.7	26.5	8.0	16.0	4.0	3.0	6.4	31.88	160.0

尖齿链 Sharp Top Chains

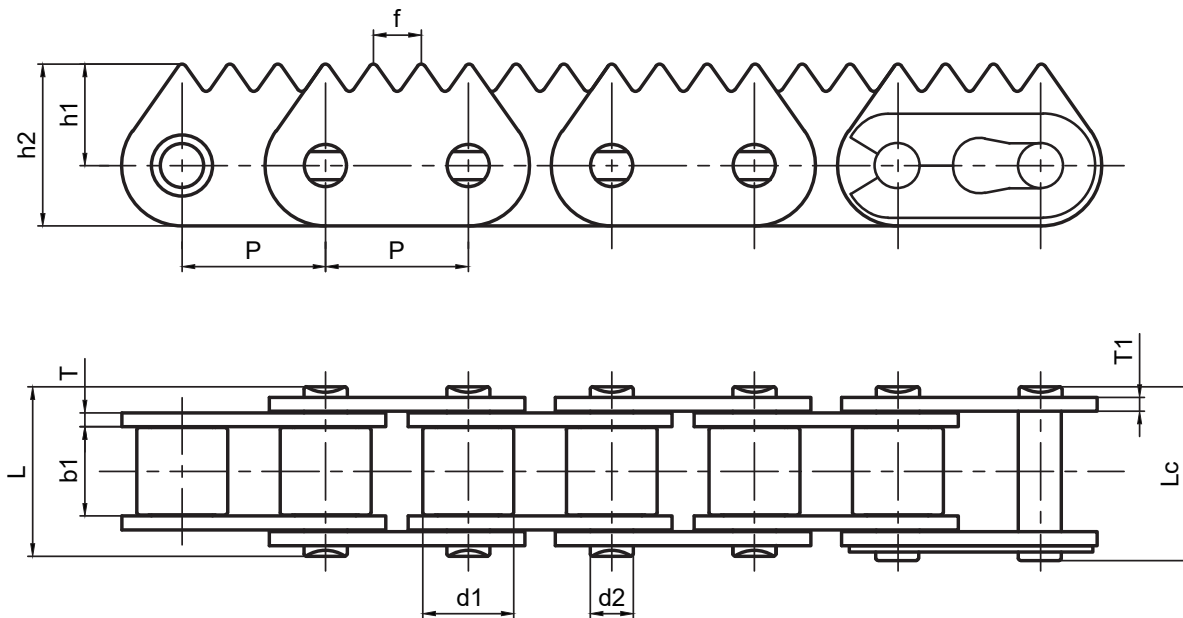

征和链号 CHOHO Chain No.	节距	滚子直径	销轴直径	内节内宽	销轴长度		链板尺寸					抗拉强度
	Pitch	Roller diameter	Pin diameter	Width between inner plates	Pin length		Attachment dimensions					Ultimate tensile strength
	P	d1 max	d2 max	b1 min	L max	Lc max	h2 max	f	h1	T	T1	Q min
	mm	mm	mm	mm	mm	mm	mm	mm	mm	mm	mm	kN
C12B-1325-1	19.050	12.07	5.72	11.68	22.5	24	21.5	6.4	13.5	1.9	1.9	29.0

输送带
Conveyor Chains

曳引链
Leaf Chains

传动链
Driving Chains

键槽和螺纹
Keyway And Thread

A系列滚子链轮
Sprocket-A-Series

B系列滚子链轮
Sprocket-B-Series

双节距链轮
Double Pitch Sprocket

双驱链轮
Double-Drive Sprocket

同步带轮
Synchronous Pulley

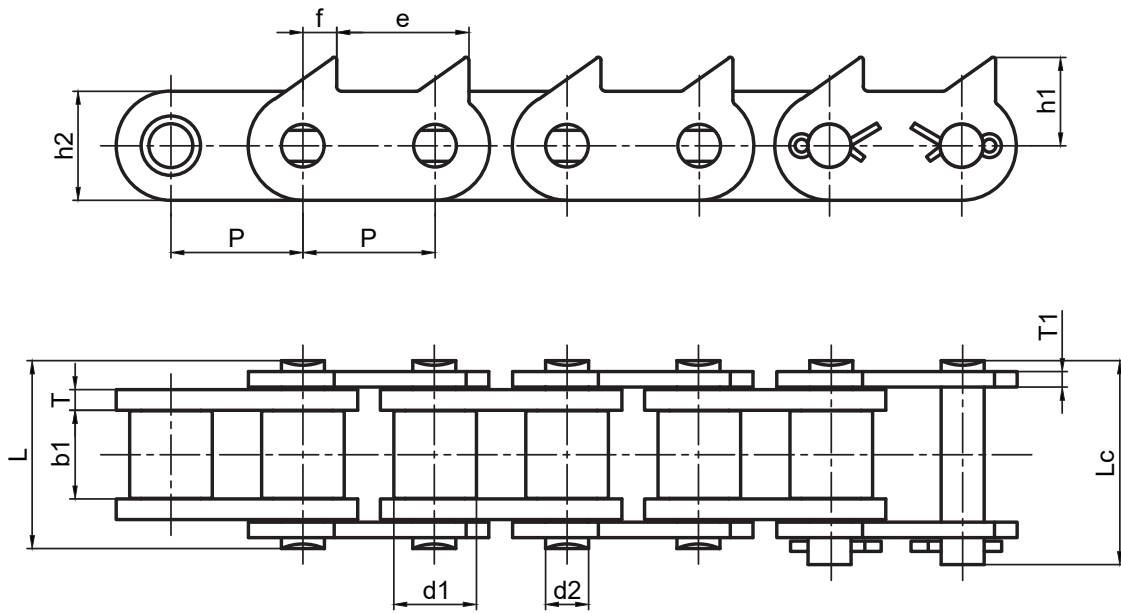

征和链号 CHOHO Chain No.	节距	滚子直径	销轴直径	内节内宽	销轴长度		链板尺寸					抗拉强度	平均抗拉强度	
	Pitch	Roller diameter	Pin diameter	Width between inner plates	Pin length		Attachment dimensions					Ultimate tensile strength	Average Tensile Strength	
	P	d1 max	d2 max	b1 min	L max	Lc max	h2 max	f	e	h1	T	T1	Q min	Q ₀
	mm	mm	mm	mm	mm	mm	mm	mm	mm	mm	mm	mm	kN	kN
C16B-1161-1	25.400	15.88	8.28	17.02	36.1	39.2	21.0	6.5	25.4	17.0	4.0	3.0	60.0	72.5

输送机
Conveyor Chains

曳引链
Leaf Chains

传动链
Driving Chains

键槽和螺纹
Keyway And Thread

A 系列滚子链轮
Sprocket - A Series

B 系列滚子链轮
Sprocket - B Series

双节距链轮
Double Pitch Sprocket

双驱链轮
Double-Drive Sprocket

同步带轮
Synchronous Pulley

尖齿链 Sharp Top Chains

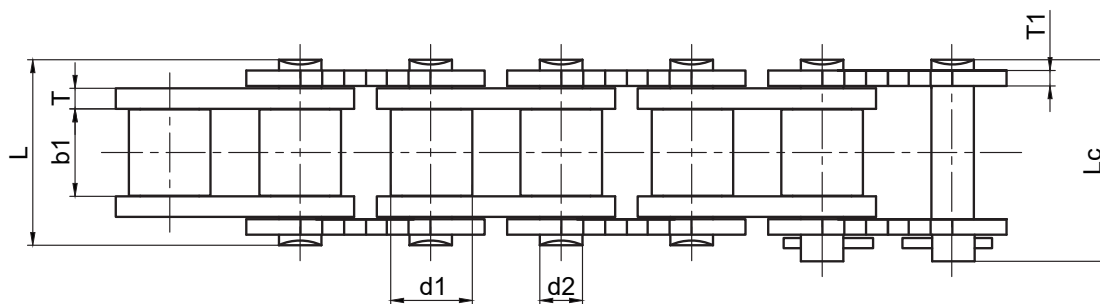
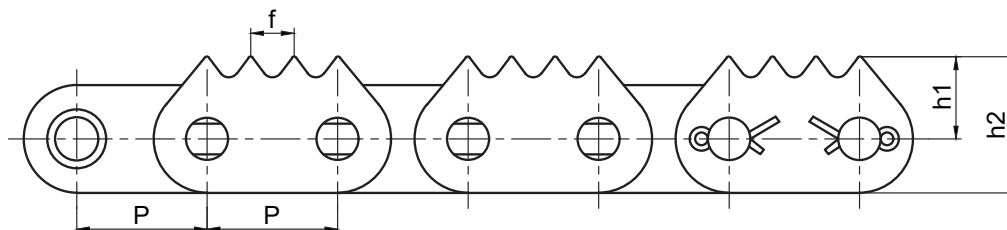

征和链号 CHOHO Chain No.	节距	滚子直径	销轴直径	内节内宽	销轴长度		链板尺寸						抗拉强度
	Pitch	Roller diameter	Pin diameter	Width between inner plates	Pin length		Attachment dimensions						Ultimate tensile strength
	p	d1 max	d2 max	b1 min	L max	Lc max	h1 max	h2	h3	f	T	T1	Q min
	mm	mm	mm	mm	mm	mm	mm	mm	mm	mm	mm	mm	kN
C16B-1170-1	25.400	15.88	8.28	17.02	36.1	39.2	21.0	16.0	26.5	8.47	3.0	3.0	60.0

输送链
Conveyor Chains

曳引链
Leaf Chains

传动链
Driving Chains

键槽和螺纹
Keyway And Thread

A系列滚子链轮
Sprocket-A-Series

B系列滚子链轮
Sprocket-B-Series

双节距链轮
Double Pitch Sprocket

双驱链轮
Double-Drive Sprocket

同步带轮
Synchronous Pulley

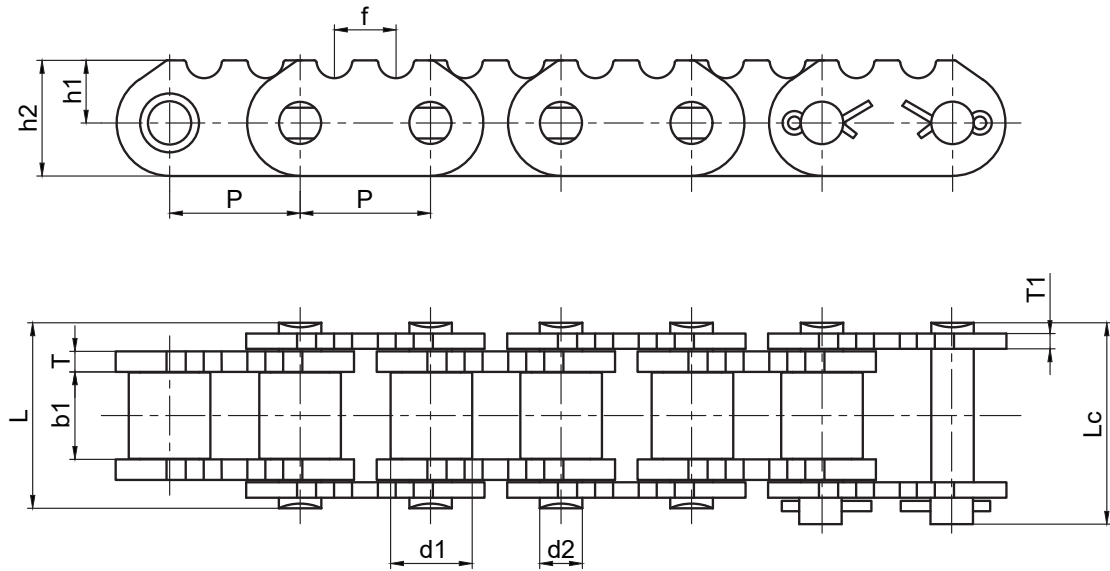

征和链号 CHOHO Chain No.	节距	滚子直径	销轴直径	内节内宽	销轴长度		链板尺寸					抗拉强度
	Pitch	Roller diameter	Pin diameter	Width between inner plates	Pin length		Attachment dimensions					Ultimate tensile strength
	P	d1 max	d2 max	b1 min	L max	Lc max	h2 max	f	h1	T	T1	Q min
	mm	mm	mm	mm	mm	mm	mm	mm	mm	mm	mm	kN
C16B-1180-1	25.400	15.88	8.28	17.02	36.1	39.2	22.5	12.0	12.2	3.0	3.0	60.0

输送机
Conveyor Chains

曳引链
Leaf Chains

传动链
Driving Chains

键槽和螺纹
Keyway And Thread

A系列滚子链轮
Sprocket - A Series

B系列滚子链轮
Sprocket - B Series

双节距链轮
Double Pitch Sprocket

双驱链轮
Double-Drive Sprocket

同步带轮
Synchronous Pulley

尖齿链 Sharp Top Chains

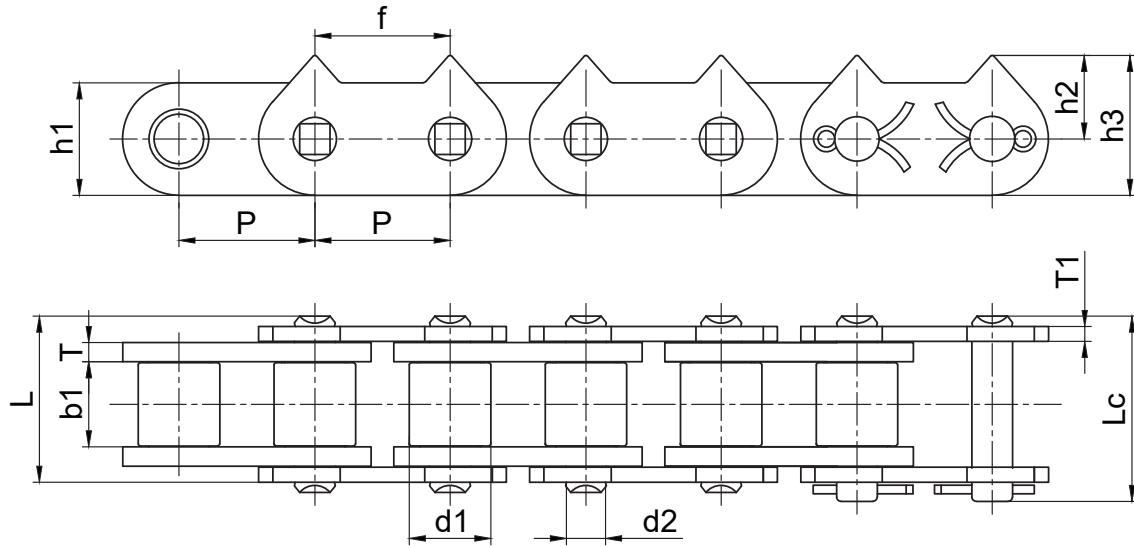

征和链号 CHOHO Chain No.	节距	滚子直径	销轴直径	内节内宽	销轴长度		链板尺寸						抗拉强度
	Pitch	Roller diameter	Pin diameter	Width between inner plates	Pin length		Attachment dimensions						Ultimate tensile strength
	p	d1 max	d2 max	b1 min	L max	Lc max	h1 max	h2	h3	f	T	T1	Q min
	mm	mm	mm	mm	mm	mm	mm	mm	mm	mm	mm	mm	kN
C20B-1350-1	31.750	19.05	10.19	19.56	40.8	45.2	26.3	19.8	33.0	31.75	4.5	3.5	95.0

输送机
Conveyor Chains

曳引链
Leaf Chains

传动链
Driving Chains

键槽和螺纹
Keyway And Thread

A系列滚子链轮
Sprocket-A-Series

B系列滚子链轮
Sprocket-B-Series

双节距链轮
Double Pitch Sprocket

双驱链轮
Double-Drive Sprocket

同步带轮
Synchronous Pulley

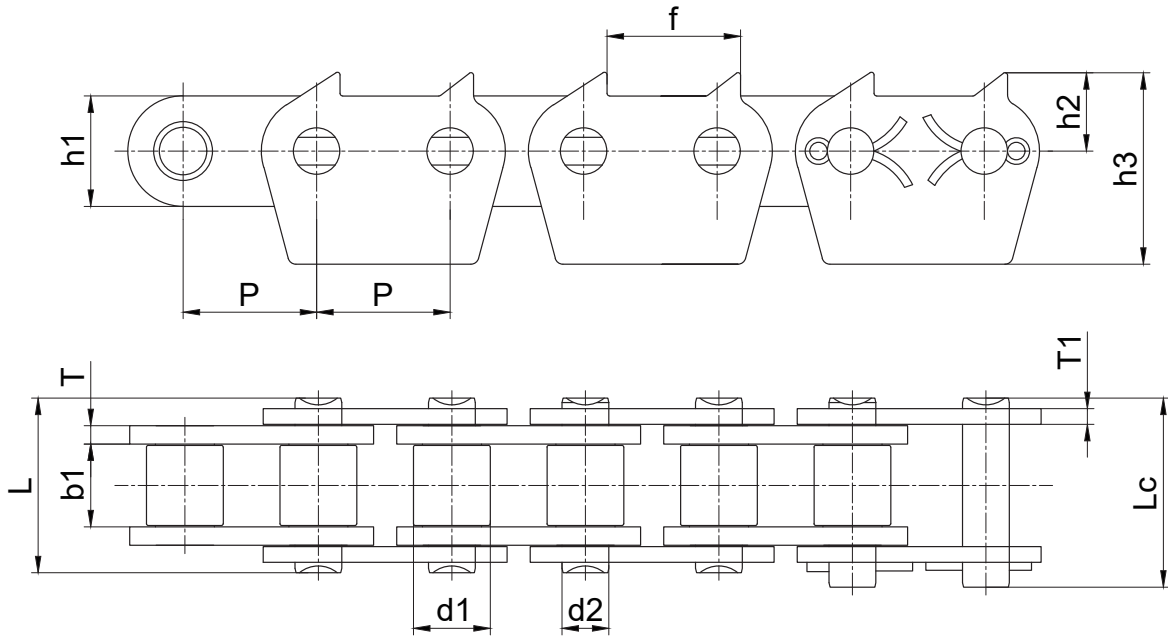

征和链号 CHOHO Chain No.	节距	滚子直径	销轴直径	内节内宽	销轴长度		链板尺寸						抗拉强度
	Pitch	Roller diameter	Pin diameter	Width between inner plates	Pin length		Attachment dimensions						Ultimate tensile strength
	p	d1 max	d2 max	b1 min	L max	Lc max	h1 max	h2	h3	f	T	T1	Q min
	mm	mm	mm	mm	mm	mm	mm	mm	mm	mm	mm	mm	kN
C32B-1874-1	50.800	29.21	17.81	30.99	66.5	72	42.0	30.0	73.0	50.80	7.0	6.0	250.0

输送机
Conveyor Chains

曳引链
Leaf Chains

传动链
Driving Chains

键槽和螺纹
Keyway And Thread

A 系列滚子链轮
Sprocket - A Series

B 系列滚子链轮
Sprocket - B Series

双节距链轮
Double Pitch Sprocket

双驱链轮
Double-Drive Sprocket

同步带轮
Synchronous Pulley

尖齿链 Sharp Top Chains

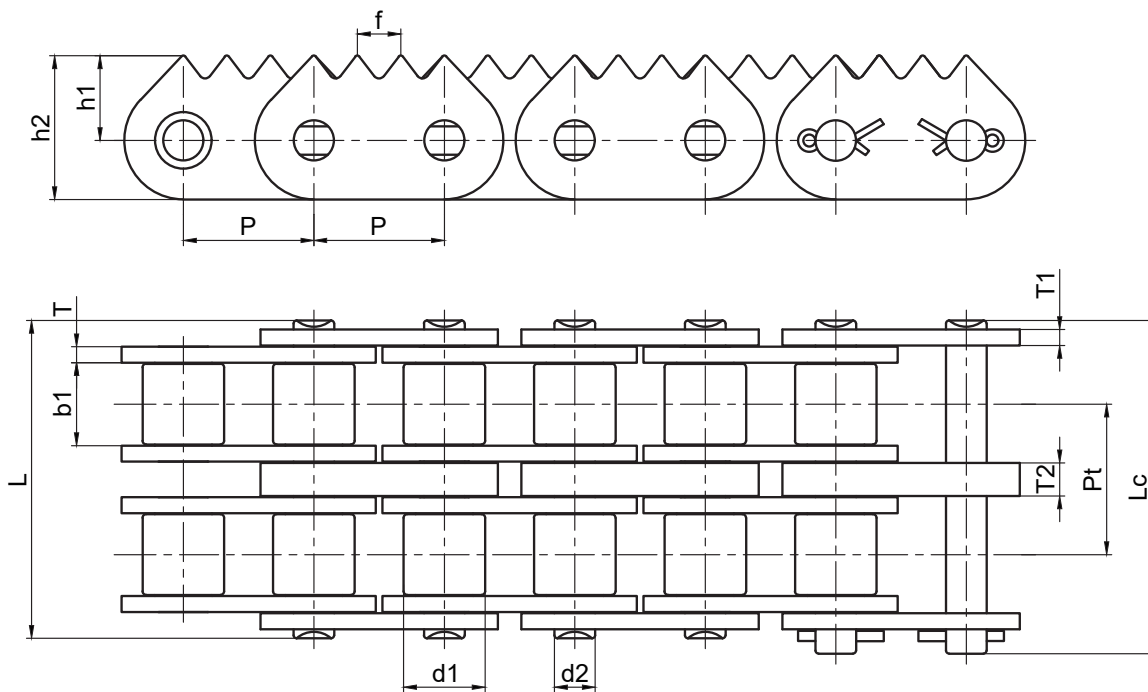

征和链号 CHOHO Chain No.	节距	滚子 直径	销轴 直径	内节 内宽	销轴长度		链板尺寸						排距	抗拉强度
	Pitch	Roller diameter	Pin diameter	Width between inner plates	Pin length		Attachment dimensions						Transverse pitch	Ultimate tensile strength
	p	d1 max	d2 max	b1 min	L max	Lc max	h1 max	h2 max	T	T1	T2	f	Pt	Q min
	mm	mm	mm	mm	mm	mm	mm	mm	mm	mm	mm	mm	mm	kN
C80-1230-2	25.4	15.88	7.94	15.75	62	65.0	16.5	28.0	3.10	3.10	6.40	8.47	29.29	113.4

输送带
Conveyor Chains

曳引链
Leaf Chains

传动链
Driving Chains

键槽和螺纹
Keyway And Thread

A系列滚子链轮
Sprocket - A-Series

B系列滚子链轮
Sprocket - B-Series

双节距链轮
Double Pitch Sprocket

双驱动链轮
Double-Drive Sprocket

同步带轮
Synchronous Pulley

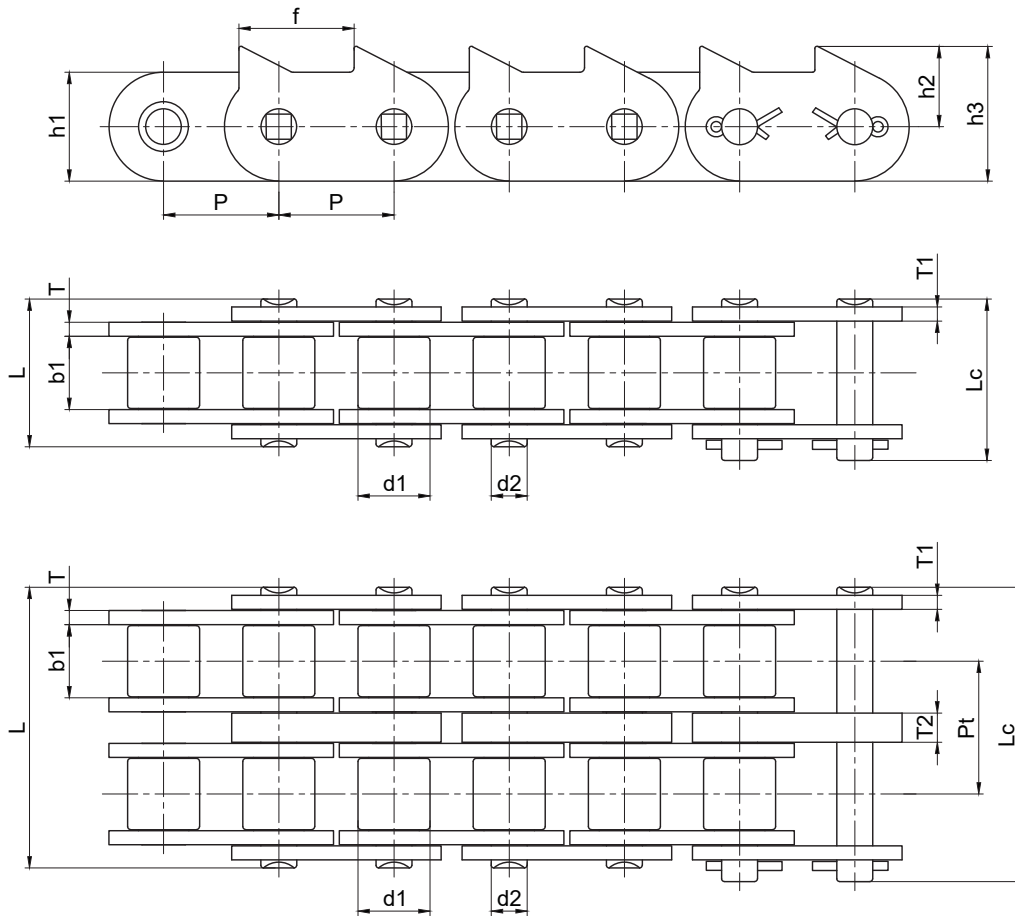

征和链号 CHOHO Chain No.	节距	滚子 直径	销轴 直径	内节 内宽	销轴长度		链板尺寸							排距	抗拉强度
	Pitch	Roller diameter	Pin diameter	Width between inner plates	Pin length		Attachment dimensions							Transverse pitch	Ultimate tensile strength
	p	d1 max	d2 max	b1 min	L max	Lc max	h1 max	h2	h3	f	T	T1	T2	Pt	Q min
	mm	mm	mm	mm	mm	mm	mm	mm	mm	mm	mm	mm	mm	mm	kN
C80-1274-1	25.4	15.88	7.94	15.75	62	65.0	24.1	18.0	30.0	25.4	3.25	3.10	/	/	56.7
C80-1274-2	25.4	15.88	7.94	15.75	62	65.0	24.1	18.0	30.0	25.4	3.25	3.10	6.40	29.29	113.4

输送带
Conveyor Chains

曳引链
Leaf Chains

传动链
Driving Chains

键槽和螺纹
Keyway And Thread

A 系列滚子链轮
Sprocket - A Series

B 系列滚子链轮
Sprocket - B Series

双节距链轮
Double Pitch Sprocket

双驱链轮
Double-Drive Sprocket

同步带轮
Synchronous Pulley

尖齿链 Sharp Top Chains

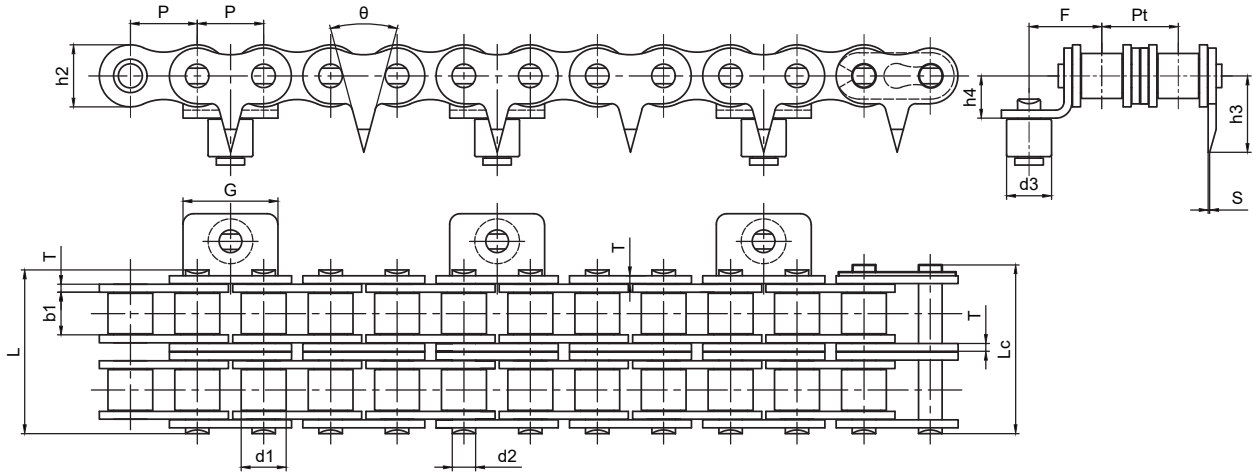

征和链号 CHOHO Chain No.	节距	滚子直径	销轴直径	内节内宽	销轴长度		链板尺寸					附板宽度	排距	齿厚	角度	抗拉强度	平均抗拉强度
	Pitch	Roller diameter	Pin diameter	Width between inner plates	Pin length		Attachment dimensions					Attachment width	Transverse pitch	Tooth thickness	Angle	Ultimate tensile strength	Average Tensile Strength
	p	d1/d3 max	d2 max	b1 min	L max	Lc max	h2 max	F	h3	h4	T	G	Pt	S	θ	Q min	Q ₀
	mm	mm	mm	mm	mm	mm	mm	mm	mm	mm	mm	mm	mm	mm	°	kN	kN
08B-ST1AV1-2	12.700	8.51	4.45	7.75	31	32	11.8	13.8	14.5	8.0	1.6	18	13.92	0.3	30	31.1	38.4

输送带
Conveyor Chains

曳引链
Leaf Chains

传动链
Driving Chains

键槽和螺纹
Keyway And Thread

A系列滚子链轮
Sprocket - A-Series

B系列滚子链轮
Sprocket - B-Series

双节距链轮
Double Pitch Sprocket

双驱链轮
Double-Drive Sprocket

同步带轮
Synchronous Pulley

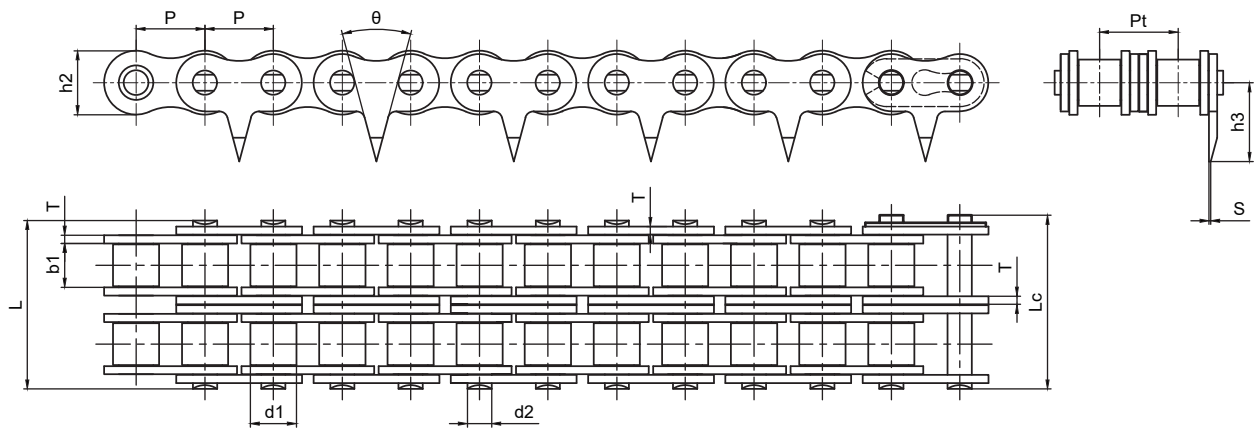

征和链号 CHOHO Chain No.	节距	滚子直径	销轴直径	内节内宽	销轴长度		链板尺寸			排距	齿厚	角度	抗拉强度	平均抗拉强度
	Pitch	Roller diameter	Pin diameter	Width between inner plates	Pin length		Attachment dimensions			Transverse pitch	Tooth thickness	Angle	Ultimate tensile strength	Average Tensile Strength
	P	d1 max	d2 max	b1 min	L max	Lc max	h2 max	h3	T	Pt	S	θ	Q min	Q ₀
	mm	mm	mm	mm	mm	mm	mm	mm	mm	mm	mm	°	kN	kN
08B-ST1A-2	12.700	8.51	4.45	7.75	31	32	11.8	14.5	1.6	13.92	0.3	30	31.1	38.4

输送带
Conveyor Chains

曳引链
Leaf Chains

传动链
Driving Chains

键槽和螺纹
Keyway And Thread

A系列滚子链轮
Sprocket - A Series

B系列滚子链轮
Sprocket - B Series

双节距链轮
Double Pitch Sprocket

双驱链轮
Double-Drive Sprocket

同步带轮
Synchronous Pulley

尖齿链 Sharp Top Chains

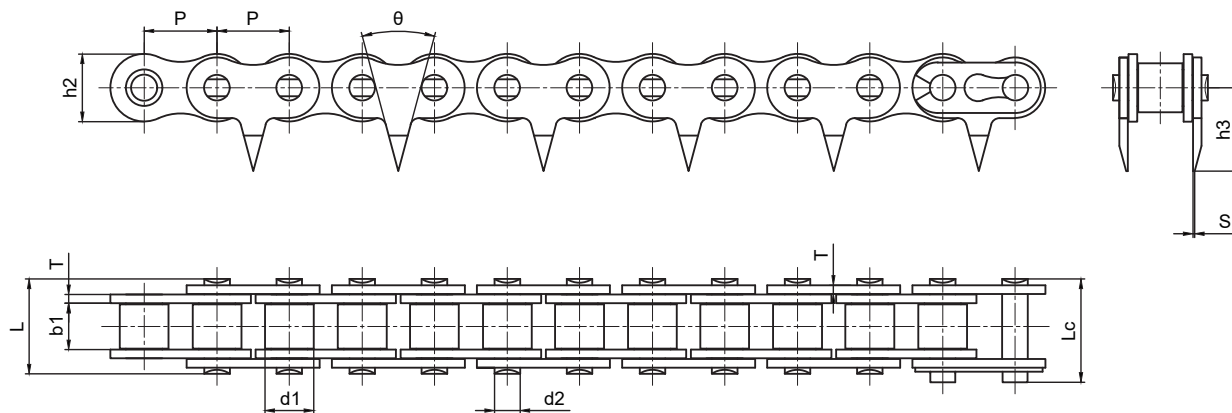

征和链号 CHOHO Chain No.	节距	滚子直径	销轴直径	内节内宽	销轴长度		链板尺寸			齿厚	角度	抗拉强度	平均抗拉强度
	Pitch	Roller diameter	Pin diameter	Width between inner plates	Pin length		Attachment dimensions			Tooth thickness	Angle	Ultimate tensile strength	Average Tensile Strength
	P	d1 max	d2 max	b1 min	L max	Lc max	h2 max	h3	T	S	θ	Q min	Q ₀
	mm	mm	mm	mm	mm	mm	mm	mm	mm	mm	°	kN	kN
08B-ST1K	12.700	8.51	4.45	7.75	16.6	18	11.8	14.5	1.6	0.3	30	18	22.2

输送链
Conveyor Chains

曳引链
Leaf Chains

传动链
Driving Chains

键槽和螺纹
Keyway And Thread

A系列滚子链轮
Sprocket - A-Series

B系列滚子链轮
Sprocket - B-Series

双节距链轮
Double Pitch Sprocket

双驱动链轮
Double-Drive Sprocket

同步带轮
Synchronous Pulley