

CHOHO HIGH-END INDUSTRIAL CHAIN-- **SUGAR MILL CHAIN**



153.67

征和高端 工业链条 **糖机链**



糖机链是指在制糖行业生产装备所使用的链条,产品覆盖制糖工业传动、提升和输送等所有制造过程。链条本身具备其特殊的弯链板结构,使之更适于带有较大冲击性的载荷传动和起动频繁的间歇性工作环
境,主要应用于采矿、冶金、工程机械等行业的较大型设备及繁重工况下的动力传动。

Sugar Mill Chain refers to chains used in the production equipment of the sugar industry, covering all manufacturing processes such as driving, lifting, and conveying in the sugar industry. The Chain itself has its special curved chain plate structure which makes it more suitable for the intermittent working environment with large impact load transmission and frequent Construction Machinery. It is mainly using in the power transmission of large equipment and heavy-duty conditions in mining, metallurgy, and engineering machinery industries.

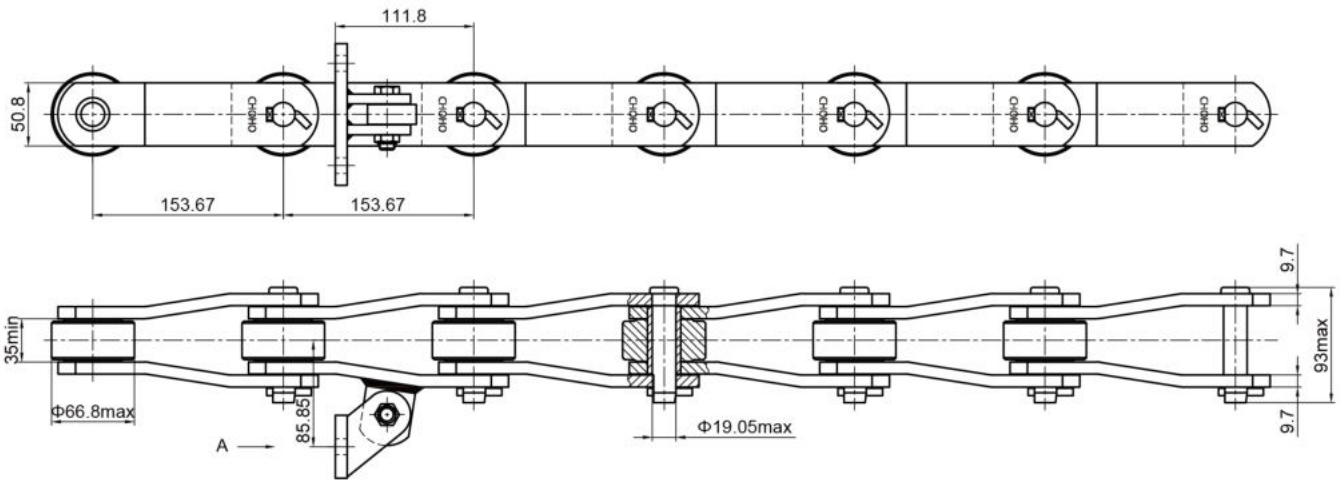

征和的糖机链旨在确保最佳质量和性能，我们的糖机链产品涵盖所有制糖行业。我们生产组合链、锻造链、焊接钢链、甘蔗链、滤汁链、甘蔗渣输送链等。通过使用合适质量的合金钢和适当的热处理工艺，可实现最高的抗重载能力和较长的磨损寿命。

CHOHO Sugar Mill chains are designed to ensure the best quality and performance, and our sugar machine chain products cover all sugar industries. We produce combined chains, forged chains, welded steel chains, sugar cane chains, juice filter chains, bagasse conveyor chains and more. Highest heavy load resistance and long wear life can be achieved by using suitable quality alloy steel and proper heat treatment process.

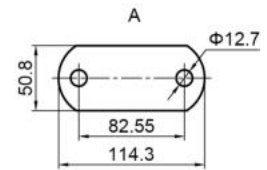

优质的原材料 High Quality Raw Materials

特定环境链条的销轴、套筒选用马氏体不锈钢。
The pin and bush of the chain in a specific environment are made of Martensitic stainless steel.



先进的热处理工艺 Advanced Heat Treatment

确保产品的韧性及强度，提高链条抗磨损、抗疲劳、抗腐蚀、抗氧化等性能
Ensured the toughness and strength of the product, and the anti-wear, anti-fatigue, anti-corrosion, anti-oxidation & other properties



领先的加工技术 Leading Technology

冲压工艺先进，产品质量稳定。
Advanced stamping technology, stable product quality.

征和是链传动行业首家A股上市公司，是国家认定的企业技术中心，拥有强大的链系统产品生产能力和研发能力，征和糖机链条以性能稳定，平稳可靠著称。

As the first A-share listed company in the chain drive industry, CHOHO is the enterprise technology center recognized by the state. It has A strong manufacturing capacity and research and development capacity of chain system products. CHOHO sugar machine chain is famous for its stable performance, stable and reliable.

- 🏢 青岛征和工业股份有限公司
QINGDAO CHOHO INDUSTRIAL CO.,LTD
- 📍 中国青岛平度市香港路112号
112 Hong Kong Road, Pingdu City, Qingdao, China
- ☎ +86 0532 8330 5969
+86 165 0532 6886 (Common to all social apps)
- ✉ jasminezhao@chohogroup.com
rebecca.ren@chohogroup.com



微信公众号
Official Wechat



征和官网
CHOHO Website

ISO 9001
Through the ISO9001
Quality System Certification
Since 1999