

# 棕榈油链 Palm Oil Chain

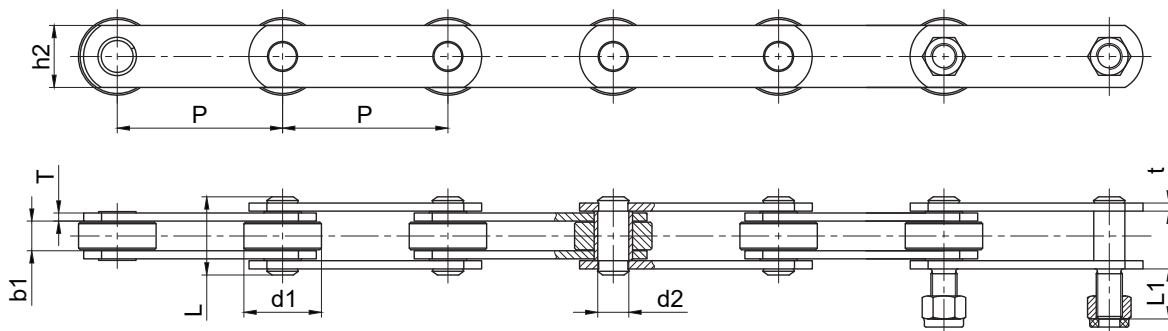

征和链号 CHOHO Chain No.	节距	内节内宽	滚子直径	销轴直径	销轴长度	加长销轴长度	链板高度	链板厚度	抗拉强度
	Pitch	Width between inner plates	Roller diameter	Pin diameter	Pin length	Lengthen the pin length	Plate height	Plate thickness	Ultimate Tensile Strength
	P	b1 min	d1 max	d2 max	L max	L1	h2	T/t	Q min
	mm	mm	mm	mm	mm	mm	mm	mm	kN
ZYP101.6V1	101.60	18.20	47.60	19.10	48.00	36.00	38.1	5.0	100.0
ZYP101.6V2	101.60	25.40	66.70	26.90	66.00	25.00	50.8	7.2	200.0
ZYP152.4V1	152.40	18.20	47.60	19.10	48.00	36.00	38.1	5.0	100.0
ZYP152.4V2	152.40	25.40	66.70	26.90	66.00	25.00	50.8	7.2	200.0
ZYP152.4V3	152.40	38.10	88.90	31.80	95.00	50.00	70.0	12/9.5	450.0

输送链  
Conveyor Chains

曳引链  
Leaf Chains

传动链  
Driving Chains

键槽和螺纹  
Keyway And Thread

A系列滚子链轮  
Sprocket-A-Series

B系列滚子链轮  
Sprocket-B-Series

双节距链轮  
Double Pitch Sprocket

双驱动链轮  
Double-Drive Sprocket

同步带轮  
Synchronous Pulley

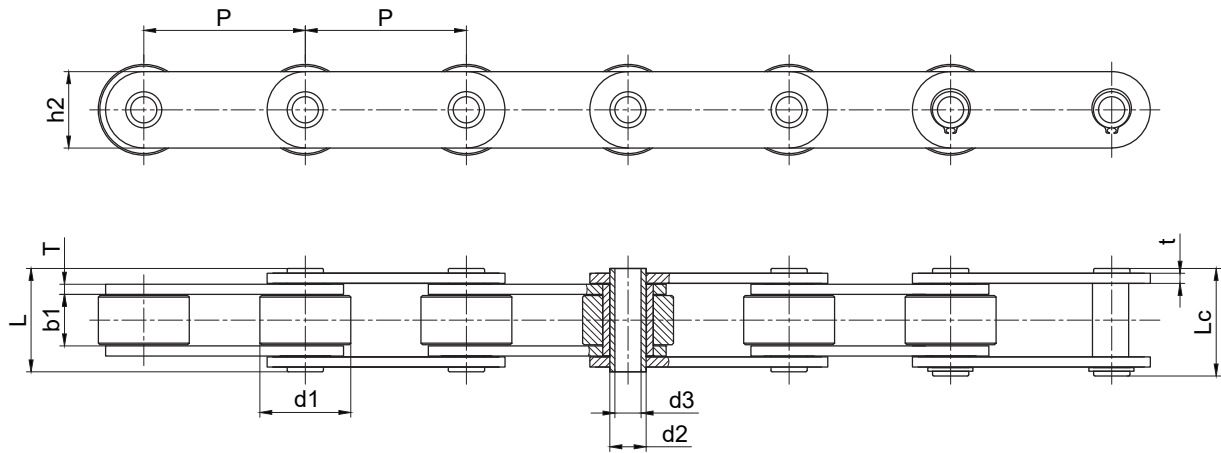

征和链号 CHOHO Chain No.	节距	内节内宽	滚子直径	销轴直径		销轴长度		链板高度	链板厚度	抗拉强度
	Pitch	Width between inner plates	Roller diameter	Pin diameter		Pin length		Plate height	Plate thickness	Ultimate Tensile Strength
	p	b1 min	d1 max	d2 max	d3 min	L max	Lc	h2	T/t	Q min
	mm	mm	mm	mm	mm	mm	mm	mm	mm	kN
ZYP101.6V1-HP	101.60	18.20	47.60	19.10	13.20	45.00	47.0	38.1	5.0	67.0
ZYP152.4V2-HP	152.40	25.40	66.70	26.90	20.10	66.00	68.0	50.8	7.2	160.0
ZYP152.4V5-HP	152.40	25.40	66.70	26.90	20.10	69.00	71.0	70.0	9.0/8.0	222.0

输送机  
Conveyor Chains

曳引链  
Leaf Chains

传动链  
Driving Chains

键槽和螺纹  
Keyway And Thread

A系列滚子链轮  
Sprocket - A Series

B系列滚子链轮  
Sprocket - B Series

双节距链轮  
Double Pitch Sprocket

双驱链轮  
Double-Drive Sprocket

同步带轮  
Synchronous Pulley