

打捆机链 Baling Machine Chains

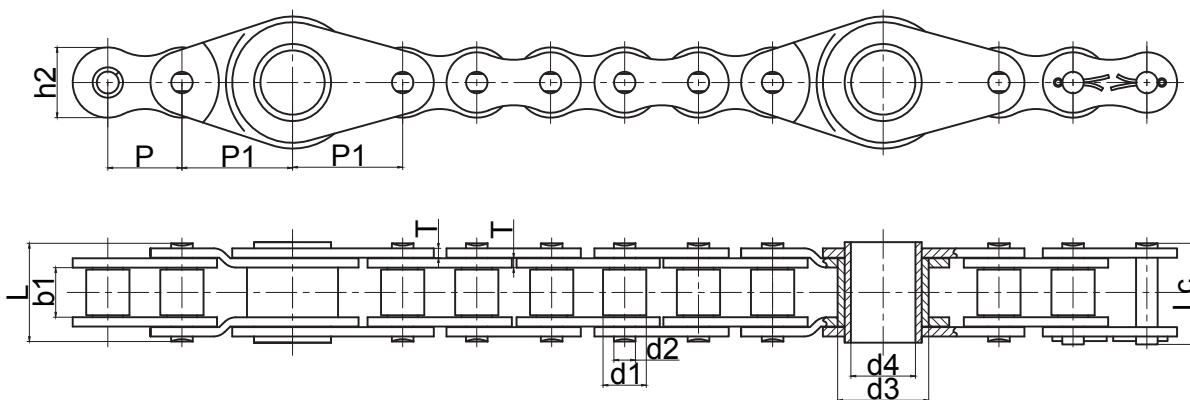

征和链号 CHOHO Chain No.	节距		滚子 直径	销轴 直径	大套筒 直径	空心销轴 内径	内节 内宽	销轴 长度		链板尺寸		抗拉 强度	平均 抗拉 强度
	P	P1	d1 max	d2 max	d3 max	d4 min	b1 min	L max	Lc max	h2 max	T	Q min	Q ₀
	mm	mm	mm	mm	mm	mm	mm	mm	mm	mm	mm	kN	kN
24AF1	38.100	56.690	22.23	11.10	47.10	33.30	25.30	50.5	54.3	36.1	4.8	127.0	170.0

GS38 链条及附件
GS38 Chain and Accessories

S 型钢制农机链及附件
S type Steel Agricultural
Chains and Accessories

A 型钢制农机链及附件
A type steel Agricultural
Chains and Accessories

C/C/A 型钢制农机链及附件
C/C/A type steel Agricultural
Chains and Accessories

水稻收割机链
Rice harvester Chains

夹持链
Clamping Chains

其他农机链及附件
Other Agricultural Chains
and Accessories

传动链
Driving Chains

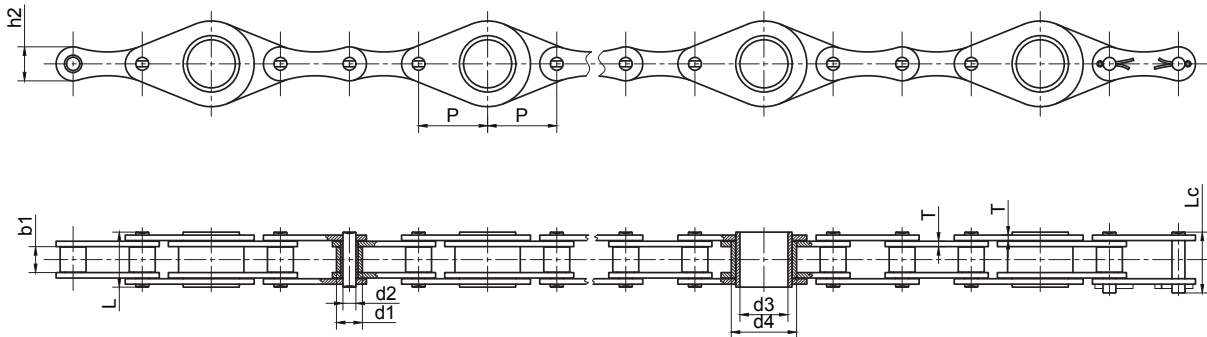

征和链号 CHOHO Chain No.	节距	滚子直径	销轴直径	大套筒 直径	空心 销轴内径	内节内宽	销轴长度		链板尺寸		抗拉强度	平均 抗拉 强度
	P	d1 max	d2 max	d3 max	d4 min	b1 min	L max	Lc max	h2 max	T	Q min	Q ₀
	mm	mm	mm	mm	mm	mm	mm	mm	mm	mm	kN	kN
CA650F3	50.800	19.05	9.53	19.05	48.00	35.30	40.4	44.7	25.0	4.0	90.0	110.0

GS38 链条及附件
GS38 Chain and Accessories

S 型钢制农机链及附件
S Type Steel Agricultural
Chains and Accessories

A 型钢制农机链及附件
A Type Steel Agricultural
Chains and Accessories

C/A 型钢制农机链及附件
C/A Type Steel Agricultural
Chains and Accessories

水稻收割机链
Rice harvester Chains

夹持链
Clamping Chains

其他农机链及附件
Other Agricultural Chains
and Accessories

传动链
Driving Chains