

GS38 母链 GS38 Parent Chain

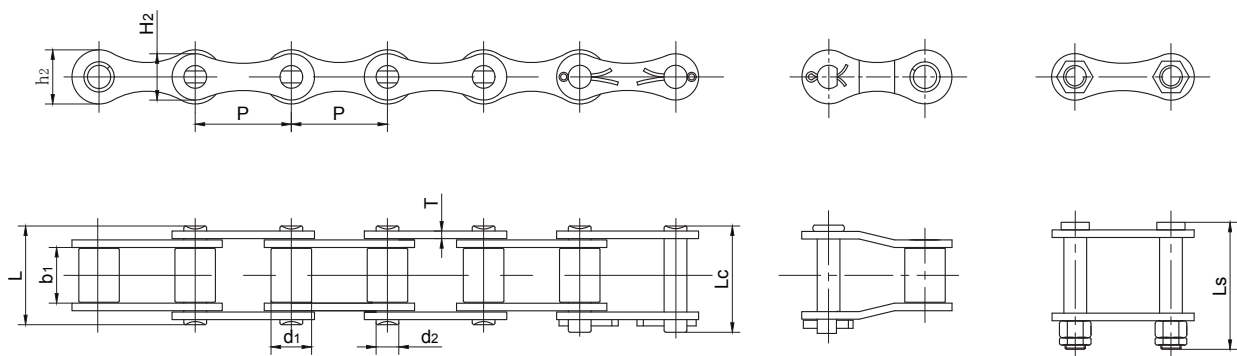

征和链号 CHOHO Chain No.	节距	滚子 直径	内节 内宽	销轴 直径	销轴长度			内链板 高度	内链板 高度	链板厚度	抗拉强度	平均抗拉 强度	每米 长重
	P	d_1 max	b_1 min	d_2 max	L max	L_c max	L_s max	h_2 max	H_2 max	T max	Q min	Q_0	q
	mm	mm	mm	mm	mm	mm	mm	mm	mm	mm	kN	kN	kg/m
GS38	38.0	16.00	22.0	9.0	39.0	43.0	50.3	21.4	18.4	3.0	45.0	60.0	2.00
GS38V1	38.0	16.00	22.0	9.0	39.0	43.0	50.3	21.4	18.4	3.0	45.0	60.0	2.00

GS38 链条及附件
GS38 Chain and Accessories

S 型钢制农具链及附件
S type steel Agricultural
Chains and Accessories

A 型钢制农具链及附件
A type steel Agricultural
Chains and Accessories

C/CV 型钢制农具链及附件
C/CV type steel Agricultural
Chains and Accessories

水稻收割机链
Rice harvester Chains

夹持链
Clamping Chains

其他农具链及附件
Other Agricultural Chains
and Accessories

传动链
Driving Chains

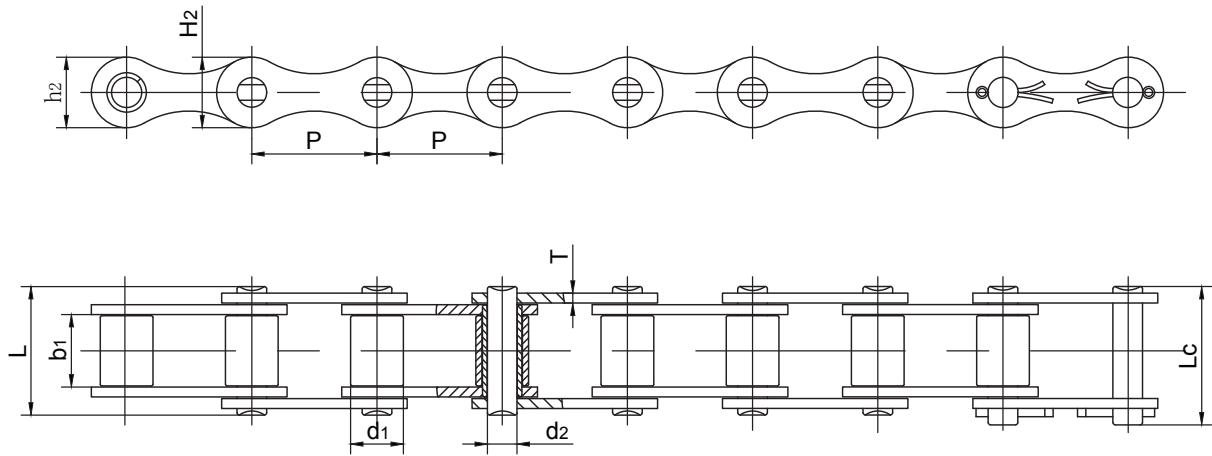

征和链号 CHOHO Chain No.	节距	滚子直径	内节内宽	销轴直径	销轴长度	内链板高度	外链板高度	链板厚度	抗拉强度	平均抗拉强度	每米长重
	P	d1 max	b1 min	d2 max	L max	h2 max	H2 max	T max	Q min	Q_0	q
	mm	mm	mm	mm	mm	mm	mm	mm	kN	kN	kg/m
GS38T	38.0	16.00	22.0	9.0	39.0	21.4	21.4	3.0	45.0	60.0	2.04

GS38 母链 GS38 Parent Chain

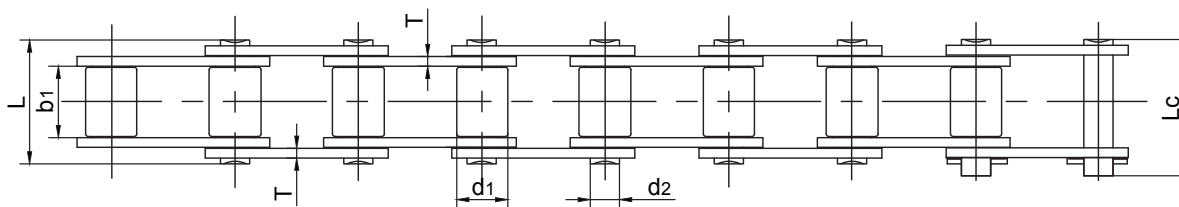
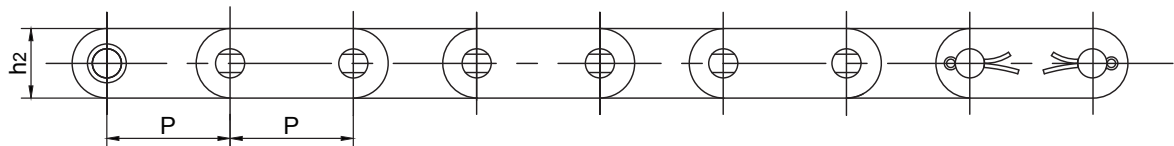

征和链号 CHOHO Chain No.	节距	滚子直径	内节内宽	销轴直径	销轴长度		内链板高度	链板厚度	抗拉强度	平均抗拉强度	每米长重
	P	d1 max	b1 min	d2 max	L max	Lc max	h2 max	T max	Q min	Q ₀	q
	mm	mm	mm	mm	mm	mm	mm	mm	kN	kN	kg/m
CGS38	38.0	15.88	22.0	9.00	39.0	43.0	21.5	3.0	56.0	60.0	2.39

GS38 链条及配件
GS38 Chain and Accessories

S 型钢制农链及配件
S type steel Agricultural
Chains and Accessories

A 型钢制农链及配件
A type steel Agricultural
Chains and Accessories

CCA 型钢制农链及配件
CCA type steel Agricultural
Chains and Accessories

水稻收割机链
Rice harvester Chains

夹持链
Clamping Chains

其他农链及配件
Other Agricultural Chains
and Accessories

传动链
Driving Chains

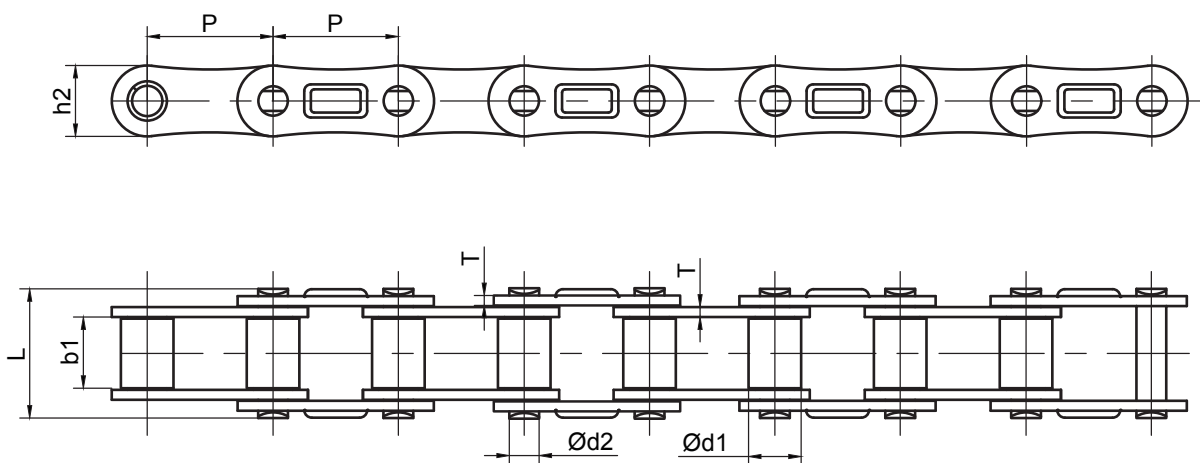

征和链号 CHOHO Chain No.	节距	滚子直径	内节内宽	销轴直径	销轴长度		内链板高度	链板厚度	抗拉强度	平均抗拉强度	每米长重
	P	d1 max	b1 min	d2 max	L max	Lc max	h_2 max	T max	Q min	Q_0	q
	mm	mm	mm	mm	mm	mm	mm	mm	kN	kN	kg/m
GS38K	38.0	16.00	22.0	9.00	39.0	/	21.5	3.0	45.0	60.0	2.29