

## 产品参数 Product Parameters

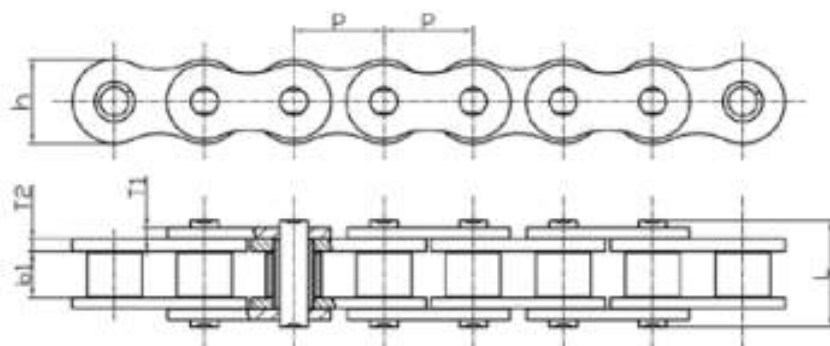

**耐磨系列：**引入合金材料，套筒为卷制套筒，提升产品强度和耐磨性。

Wear-resistant series: Made by alloy materials, formed bushing, improving product strength and wear resistance.

规格及大类 Specifications and Series		主要特点 Features								主要特性 Performance	推荐排量 cc Application By cc
产品大类 Series	规格 Model	规格 Model	内节内宽 Inner width	链板厚度 Plate Thickness	滚子直径 Roller Diameter	套筒 Bush	销轴 长度 Pin length	密封圈 状态 Ring Type	接头形态 Connecting Link	拉力 kN ≥ Tensile Strength	
		P	b1	T1/T2	L						
耐磨系列 Wear-resistant series	415H	12.7	4.8	1.5/1.5	7.77	有缝 Curved	13.3	无 N/A	环接 Connecting	16	≤70
	420	12.7	6.35	1.5/1.5	7.77	有缝 Curved	14.9	无 N/A	环接 Connecting	16	70-90
	420H	12.7	6.35	1.8/1.8	7.77	有缝 Curved	16.2	无 N/A	环接 Connecting	18	70-110
	428	12.7	7.85	1.6/1.6	8.51	有缝 Curved	16.7	无 N/A	环接 Connecting	17.8	90-125
	428H	12.7	7.85	2.0/2.0	8.51	有缝 Curved	18.5	无 N/A	环接 Connecting	20.6	100-150
	520	15.875	6.35	2.0/2.0	10.16	有缝 Curved	17.2	无 N/A	环接 Connecting	26.5	150-200
	520H	15.875	6.35	2.42/2.42	10.16	有缝 Curved	18.9	无 N/A	环接 Connecting	30.5	150-200
	525H	15.875	7.94	2.42/2.42	10.16	有缝 Curved	20.5	无 N/A	环接 Connecting	31	150-250

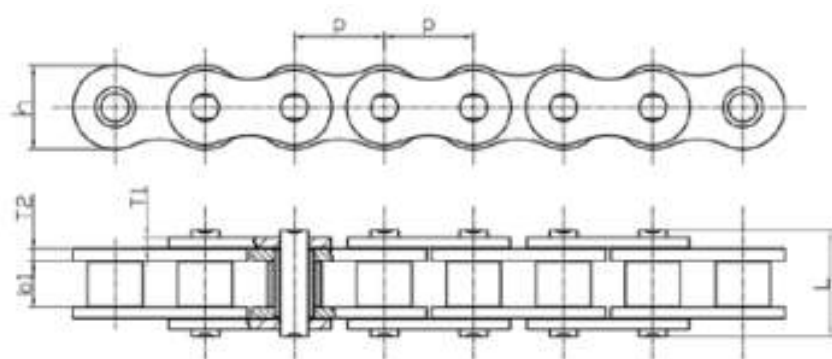

**强化系列:** 引入无缝套筒、O型密封圈技术, 确保更长的使用寿命最低限度的维护。

Super series: seamless bushing and O-ring seal ensure longer service life and minimum maintenance.

规格及大类 Specifications and Series		主要特点 Features								主要特性 Performance	推荐排量 cc Application By cc
产品大类 Series	规格 Model	规格 Model	内节内宽 Inner width	链板厚度 Plate Thickness	滚子直径 Roller Diameter	套筒 Bush	销轴 长度 Pin length	密封圈 状态 Ring Type	接头形态 Connecting Link	拉力 kN ≥ Tensile Strength	
		P	b1	T1/T2			L				
强化系列 Super Series	420HS	12.7	6.35	1.8/1.8	7.77	无缝 Solid	16.2	无 N/A	环接 Connecting	17	70-110
	428HS	12.7	7.85	2.0/2.0	8.51	无缝 Solid	18.5	无 N/A	环接 Connecting	20.6	100-150
	428HDS	12.7	7.85	2.0/2.0	8.51	无缝 Solid	19	无 N/A	环接 Connecting	21	125-190
	520HDS	15.875	6.35	2.42/2.42	10.16	无缝 Solid	19.3	无 N/A	环接 Connecting	31	150-250
	520HS	15.875	6.35	2.42/2.42	10.16	无缝 Solid	18.9	无 N/A	环接 Connecting	30.5	150-200
	530HS	15.875	9.4	2.42/2.42	10.16	无缝 Solid	22.2	无 N/A	环接 Connecting	30.5	150-250
	415UO	12.7	4.8	1.5/1.5	7.77	无缝 Solid	15.9	O型 O Ring	环铆 / 打孔 Connecting/ Split	17.8	100-150
	420O	12.7	6.35	1.5/1.5	7.77	无缝 Solid	17.5	O型 O Ring	环铆 / 打孔 Connecting/ Split	16	25KW 电摩 electric motorcycle
	428HO	12.7	7.9	2.0/2.0	8.51	无缝 Solid	21.9	O型 O Ring	环铆 / 打孔 Connecting/ Split	21	150-200
	520O2	15.875	6.35	1.8/1.8	10.22	无缝 Solid	19.4	O型 O Ring	环铆 / 打孔 Connecting/ Split	31	250-450
525HO	15.875	7.94	2.42/2.42	10.16	无缝 Solid	23.6	O型 O Ring	环铆 / 打孔 Connecting/ Split	33	150-300	

# 产品参数 Product Parameters

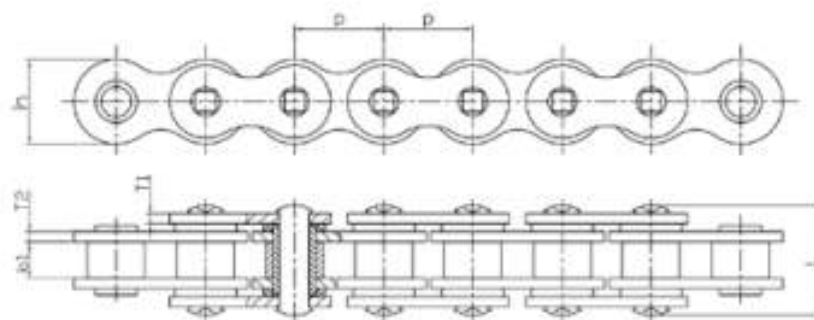

**超强系列:** 引入 4 唇密封圈的专利 X 型密封圈, 具有低摩擦阻力、高耐磨特点, 显著增加了链条的使用寿命。  
 Professional Series: The patented X-shaped ring with 4-lip sealing ring, which has the characteristics of low friction and high wear resistance, significantly increases the service life of the chain.

规格及大类 Specifications and Series		主要特点 Features								主要特性 Performance	推荐排量 cc Application By cc
产品大类 Series	规格 Model	规格 Model	内节内宽 Inner width	链板厚度 Plate Thickness	滚子直径 Roller Diameter	套筒 Bush	销轴 长度 Pin length	密封圈 状态 Ring Type	接头形态 Connecting Link	拉力 kN ≥ Tensile Strength	
		P	b1	T1/T2	L						
超强系列 professional Series	420D	12.7	6.35	1.8/1.8	7.77	无缝 Solid	16.2	无 N/A	环接 Connecting	21	100-150
	520ND	15.875	6.35	2.0/2.0	10.22	无缝 Solid	17.7	无 N/A	环接 Connecting	33	200-400
	428UX	12.7	7.9	1.8/1.8	8.51	无缝 Solid	20.7	X 型 X Ring	环铆 / 打孔 Connecting/ Split	21	150-200
	520X2	15.875	6.35	2.0/2.0	10.22	无缝 Solid	19.9	X 型 X Ring	环铆 / 打孔 Connecting/ Split	33	300-600
	520UX	15.875	6.35	2.2/2.2	10.16	无缝 Solid	20.7	X 型 X Ring	环铆 / 打孔 Connecting/ Split	34	300-650
	520SX2	15.875	6.35	2.2/2.4	10.22	无缝 Solid	21	X 型 X Ring	环铆 / 打孔 Connecting/ Split	38	600-900
	525SX2	15.875	7.94	2.2/2.4	10.22	无缝 Solid	22.6	X 型 X Ring	环铆 / 打孔 Connecting/ Split	38	600-1000
	530SX2	15.875	9.4	2.2/2.4	10.22	无缝 Solid	24.1	X 型 X Ring	环铆 / 打孔 Connecting/ Split	38	600-1100
	520EX	15.875	6.35	2.52/2.52	10.22	无缝 Solid	22	X 型 X Ring	环铆 / 打孔 Connecting/ Split	42	800-1000
	525EX	15.875	7.94	2.52/2.52	10.22	无缝 Solid	23.5	X 型 X Ring	环铆 / 打孔 Connecting/ Split	42	800-1200
	530EX	15.875	9.4	2.52/2.52	10.22	无缝 Solid	25	X 型 X Ring	环铆 / 打孔 Connecting/ Split	42	800-1300
	525VZ	15.875	7.94	2.2/2.2	10.32	无缝 Solid	22.5	X 型 X Ring	环铆 / 打孔 Connecting/ Split	42	1000-1300
	530VZ	15.875	9.4	2.2/2.2	10.32	无缝 Solid	24	X 型 X Ring	环铆 / 打孔 Connecting/ Split	42	1000-1300

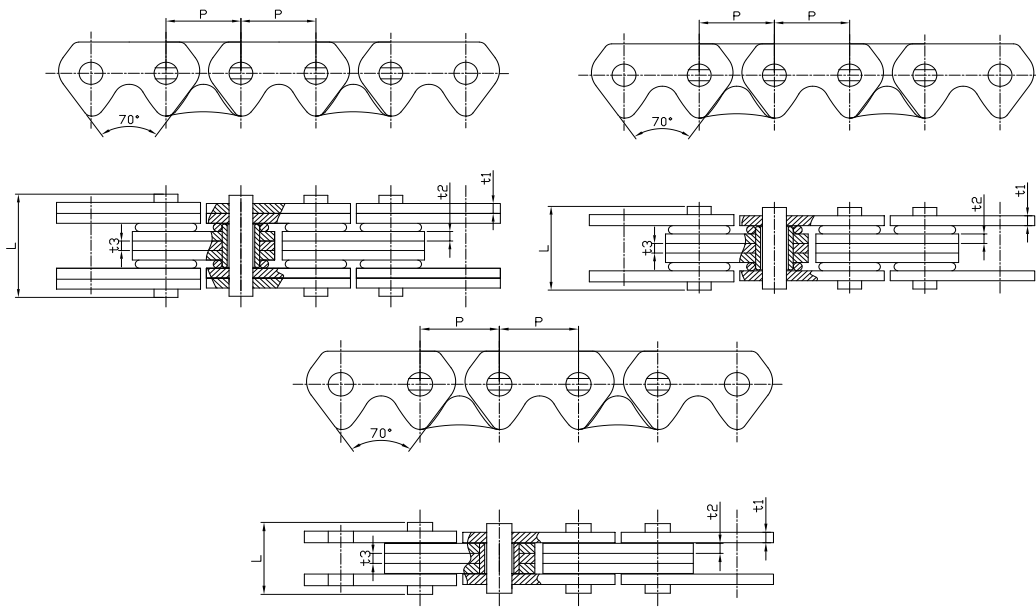

**振明链:** 基于齿形链啮合原理, 融合了滚子套筒链的结构, 振明链是集“快、静、炫、稳”于一身的真正的静音链条。  
 Zenming Chain: Based on the meshing principle of tooth shaped chains, combined with the structure of roller sleeve chains, the vibrating chain is a true silent chain that combines "fast, quiet, dazzling, and stable".

系列分类 Series classification	征和链号 CHOHO NO.	节距	片数组 合	链宽	抗拉强 度	每米重 量	链板厚度			密封圈 Seal ring	适用排量 / 功率
		Pitch	Number of Plates	Width of Chain	Tensile Strength	Weight per Meter	Chain plate thickness				Suitable Displacement/ Power
		P	pcs	L	Q min	W	t1	t2	t3		cc/KW
		mm		mm	KN	Kg/m					
振明链 Zenming	CL08CFM-5	12.7	5	14.8	22.5	0.76	2.0	1.8	1.8	X 型 X Ring	5KW-20KW
	CL08CFM-7	12.7	7	18.8	22.5	1.04	2.0	1.8	1.8	X 型 X Ring	100CC-200CC
	CL08CFS-5	12.7	5	12.8	22.5	0.74	2.0	1.8	1.8	无 N/A	100CC-150CC
	CL09CFM-5	14.29	5	16.8	30.5	1.03	2.3	2.5	2.0	X 型 X Ring	200CC-400CC
	CL09CFM-7	14.29	7	21.4	30.5	1.41	2.3	2.5	2.0	X 型 X Ring	250CC-600CC
	CL09CFS-5	14.29	5	13.3	30.5	0.99	2.3	2.5	2.0	无 N/A	100CC-350CC
	CL10CFM-5	15.875	5	17.4	42.0	1.12	2.5	2.5	2.0	X 型 X Ring	500CC-1900CC

规格 Model	主要配套客户 Main OEM Clients	车型 Motorcycle
420O	虬龙 SURREN 探骊 TALARIA	轻蜂 毒刺
428HS	新大洲本田 SUNDIRO HONDA 五羊本田 WUYANG HONDA 浙江春风动力 CFMOTO 钱江摩托 QJIANG MOTOR 比亚乔 PIAGGIO	CBF190R CB190R CF125-2 CF150-3 QJ150-19
428HO	新大洲本田 SUNDIRO HONDA 雅马哈 YAMAHA 钱江摩托 QJIANG MOTOR	SDH-150 JYM250
520HO	钱江摩托 QJIANG MOTOR 宗申摩托 ZONGSHEN MOTOR 鑫源摩托 SHINERAY MOTOR 飞肯 FEKON MOTOR	BJ250 ZS250 XY250 赛科龙 RX3 CYCLO RX3
525HO	钱江摩托 QJIANG MOTOR	QJ250-J BJ300
530HO	钱江摩托 QJIANG MOTOR 鑫源摩托 SHINERAY MOTOR	QJ350 XY300
520O2	浙江春风动力 CFMOTO	300

规格 Model	主要配套客户 Main OEM Clients	车型 Motorcycle
520HX	金城摩托 JINCHENG MOTOR 浙江春风动力 CFMOTO 比亚乔 PIAGGIO	JC250 250 250
520X2	隆鑫 LONCIN	350 RR525
520UX	本田 HONDA 豪爵 HAOJUE 隆鑫 LONCIN	400 500 650
520SX2	鑫源摩托 SHINERAY MOTOR 宗申摩托 ZONGSHEN MOTOR 莫里尼 MOTO MORINI	SR400 SR500 SR600 R23 R24 文佐 650
525SX2	钱江摩托 QJIANG MOTOR	Benelli-BJ600GS 黄龙 BN600i 黄龙 BJ600GS TNT 600 500cc 车型
525EX	宝马摩托 BMW MOTOR 摩瑞机车 MOTRAC	K08 800